

# Acuvim L

## Multifunction Power & Energy Meter Datasheet



### DESCRIPTION

Designed for a wide range of standard metering project, the Acuvim L is a multifunction power meter that combines value and high-performance with easy integration into panel or device monitoring applications. With multiple communication options including Modbus-RTU, PROFINET, Modbus-TCP, and BACnet-IP through optional expansion modules and revenue grade accuracy, the Acuvim L can be configured as either a panel-mount device, as a DIN rail mount transducer, or installed in a pre-configured, pre-wired AcuPanel for extreme protection in even the toughest application environment.



### FEATURES

- + EL Revenue Grade: ANSI C12.20 class 0.2 & IEC 62053-22 class 0.2s
- + CL Revenue Grade: ANSI C12.20 class 0.5 & IEC 62053-22 class 0.5s
- + 4th CT input – Measure neutral current
- + Dual Ethernet Ports with both RSTP bridge daisy-chain mode and separately configurable network
- + Data Logging available in 8MB, and 8GB with WEB2 module
- + Designed with industry - leading cybersecurity
- + Available compatibility with multiple CT output options including 5A, RCT (Rogowski), or 333mV
- + Modbus-RTU & BACnet MS/TP ready. Optional modules add support for multiple industrial protocols & interfaces such as Modbus-TCP, BACnet-IP, & Wi-Fi
- + Offers 512 samples/cycle sampling rate, with 1s Modbus data update rate

## KEY FEATURES

### Communication

- + Modbus RTU Protocol and BACnet MS/TP via RS485
- + Wi-Fi and Ethernet Communication Channels (Modbus TCP, BACnet IP, HTTP, SMTP, SNMP, HTTPs, Post, FTP, PROFINET)
- + Dual RJ45 ports with RSTP daisy-chain and two individually configurable Ethernet ports

### Data Logging

- + Acuvim L meters offer three, assignable historical logs and a real time clock to record many metering parameters with accurate timestamping. Add the AXM-WEB2 module to expand the memory to 8GB with an adjustable log size.
- + WEB2 module offers additional granularity to data logging with 1 second interval timing, max/min/average and instantaneous reading for real time parameters

### Time of Use

- + Users can assign up to four tariffs (sharp, peak, valley, & normal) to different time periods within a day. The Acuvim L meter will calculate and accumulate energy to different tariffs according to the meter's internal clock and TOU settings.

### Remote Access and Correction

- + Use "Remote Access" feature when paired with AXM-WEB2 to access meter web server via static URL
- + Remotely reverse polarity of individual CT inputs in event of incorrect wiring
- + Use phase selection to remotely correct alignment issues and map correct CT input to voltage inputs

### I/O Module

- + Expand Acuvim L I/O functionality by connecting an optional I/O module. A maximum of three modules can be used per meter. Digital input, digital output, pulse output, relay output, analogue input, and analogue output I/O modules are available.

### Alarms

- + Limits can be set for up to 16 indicated parameters with a specified time interval. Parameters that are over or under the setting limit and persist longer than the specified time interval will be recorded and trigger the Alarm DO. Choose from 80 available parameters.

### Flexible Current Transformer Options

- + The Acuvim L is directly compatible with Rogowski coils plus a variety of other current transformer outputs including 5A, 1A, and 333mV. All CTs are available from Accuenergy.

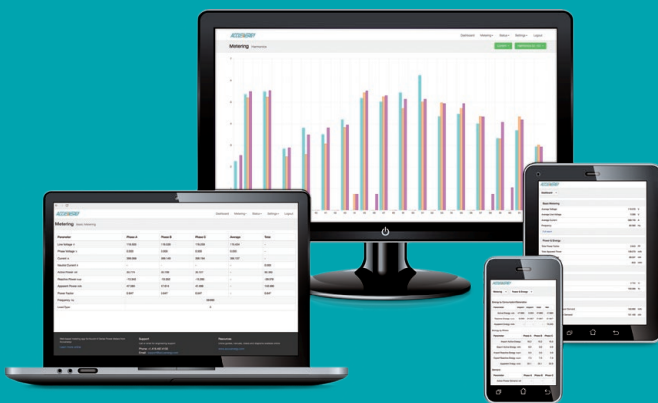

## APPLICATIONS

- + Submetering and billing allocation
- + Energy Management Systems
- + Measurement & Verification
- + Building Automation and IoT
- + SCADA Systems
- + Commercial tering, LEED 50001, and sustainability standards
- + Switchgear and switchboard monitoring

## SPECIFICATIONS

### Metering

PARAMETERS		ACCURACY	RESOLUTION	RANGE
Voltage		0.1%	0.1V	10V~1000kV
Current		0.1%	0.1mA	5mA~50000A
Power		EL: 0.2%, CL: 0.5%	1W	-9999MW~9999MW
Reactive Power		EL: 0.2%, CL: 0.5%	1var	-9999Mvar~9999Mvar
Apparent Power		EL: 0.2%, CL: 0.5%	1VA	0~9999MVA
Power Demand		EL: 0.2%, CL: 0.5%	1W	-9999MW~9999MW
Reactive Power Demand		EL: 0.2%, CL: 0.5%	1var	-9999Mvar~9999Mvar
Apparent Power Demand		EL: 0.2%, CL: 0.5%	1VA	0~9999MVA
Power Factor		EL: 0.2%, CL: 0.5%	0.001	-1.000~1.000
Frequency		0.1%	0.001Hz	45.00~65.00Hz
Energy	Primary 0.1	EL: 0.2, CL: 0.5%	0.1kWh	0-99999999.9kWh
	Primary 0.001	EL: 0.2, CL: 0.5%	0.001kWh	0-999999.999kWh
	Secondary	EL: 0.2, CL: 0.5%	0.001kWh	0-999999.999kWh
Reactive Energy	Primary 0.1	EL: 0.2, CL: 0.5%	0.1kvarh	0-99999999.9kvarh
	Primary 0.001	EL: 0.2, CL: 0.5%	0.001kvarh	0-999999.999kvarh
	Secondary	EL: 0.2, CL: 0.5%	0.001kvarh	0-999999.999kvarh
Apparent Energy	Primary 0.1	EL: 0.2, CL: 0.5%	0.1kVAh	0-99999999.9kVAh
	Primary 0.001	EL: 0.2, CL: 0.5%	0.001kVAh	0-999999.999kVAh
	Secondary	EL: 0.2, CL: 0.5%	0.001kVAh	0-999999.999kVAh
Harmonics		1.0%	0.10%	
Phase Angle		2.0%	0.1°	0.0°~359.9°
Unbalance Factor		2.0%	0.10%	0.0%~100.0%
Running Time			0.01h	0~9999999.99h

### Input

#### CURRENT INPUTS (EACH CHANNEL)*w*

Nominal Current Options	① 5A, ② 1A, ③ 333mV, ④ Rogowski Coil
Metering Range	① 0-10A, ② 0-2A, ③ 0-400mV, ④ 0-400mV
Pickup Current	① 5mA, ② 1mA, ③ 0.25mV, ④ 0.25mV
Withstand	20Arms Continuous, 100Arms for 1 second, Non-Recurring
Burden	0.05VA (Typical) @ 5A RMS
Accuracy	0.1% at Reading

#### VOLTAGE INPUTS (EACH CHANNEL)

Nominal Full Scale	480Vac L-N, 828Vac L-L
Withstand	1500Vac Continuous 2500Vac, 50/60Hz for 1 Minute
Input Impedance	2MΩ per Phase
Metering Frequency	45Hz~65Hz
Pickup Voltage	10Vac
Accuracy	0.1% at Reading

#### ENERGY ACCURACY

Active	EL: Class 0.2s (According to IEC 62053-22), Class 0.2 (According to ANSI C12.20) CL: Class 0.5s (According to IEC 62053-22), Class 0.5 (According to ANSI C12.20)
Reactive	Class 2 (According to IEC 62053-23)

### Input

#### HARMONIC RESOLUTION

Metered Value	EL:63 <sup>rd</sup> Harmonic, CL: 31 <sup>st</sup> Harmonic
---------------	---

#### Communications

<b>Modbus-RTU or BACnet MS/TP</b>	Modbus-RTU 2-Wire Shielded Twisted Pair Cable Connection 2400~115200 bps
<b>SECOND RS-485 PORT (OPTIONAL MODULE)</b>	Same as the primary RS485 port Baud Rate: 4800~38400 bps
<b>ETHERNET (OPTIONAL MODULE)</b>	Ethernet 10M/100M BaseT MODBUS-TCP DNP 3.0 V2 Over IP Level 2 IEC 61850 2nd Ed. SNMP V3 BACnet-IP HTTP/HTTPs Webserver HTTP/HTTPs, FTP data post SMTP MQTT NTP PROFINET

## SPECIFICATIONS

### I/O Options

#### DIGITAL INPUT

Input Type	Dry
Input Resistance	100k $\Omega$
Input Voltage Range	20~160 Vac/dc
Input Current (Max)	2mA
Start Voltage	15V
Stop Voltage	5V
Pulse Frequency (Max)	100Hz, 50% Duty Ratio (5ms ON and 5ms OFF)
SOE Resolution	2ms

#### DIGITAL OUTPUT (DO) (PHOTO-MOS)

Voltage Range	0~250Vac/dc
Load Current	100mA (Max)
Output Frequency	25Hz, 50% Duty Ratio (20ms ON, 20ms OFF)
Isolation Voltage	2500Vac

#### RELAY OUTPUT (RO) (NO, Form A)

Switching Voltage (Max)	250Vac, 30Vdc
Load Current	5A (R), 2A (L)
Set Time	10ms (Max)
Contact Resistance	30m $\Omega$ (Max)
Isolation Voltage	2500Vac
Mechanical Life	1.5x10 <sup>7</sup>

#### ANALOG OUTPUT (AO)

Output Range	0~5V, 0~20mA 1~5V, 4~20mA Optional
Accuracy	0.50%
Temperature Drift	50ppm/°C Typical
Isolation Voltage	500Vdc
Open Circuit Voltage	15V

#### ANALOG INPUT (AI)

Input Range	0~5V, 0~20mA 1~5V, 4~20mA Optional
Accuracy	0.20%
Temperature Drift	50ppm/°C Typical
Isolation Voltage	500Vdc

#### POWER SUPPLY FOR DI (24 VDC)

Output Voltage	24Vdc
Output Current	42mA
Load (Max)	21DIs

### Control Power

Universal	AC or DC
-----------	----------

#### AC/DC CONTROL POWER

Operating Range	100~415Vac, 50/60Hz; 100~300Vdc
Burden	5W
Frequency	50/60Hz
Withstand	3250Vac, 50/60Hz for 1 minute Installation Category III (Distribution)

#### LOW VOLTAGE DC CONTROL POWER (P2V4 Option Only)

Operating Range	20~60Vdc
Burden	5W

### Operating Environment

Operating Temperature	-25°C to 70°C -13°F to 158°F
Storage Temperature	-40°C to 85°C -40°F to 176°F
Relative Humidity	5% to 95% Non-Condensing

### Standard Compliance & Certifications

Measurement Standard	IEC 62053-22; ANSI C12.20; IEC61557-12
Environmental Standard	IEC 60068-2, CE, RoHS
Safety Standard	IEC 61010-1, UL 61010-1
EMC Standard	IEC 61000-4/-2-3-4-5-6-8-11, CISPR 22, IEC 61000-3-2, IEC 61000-6-2/4, EN55011
Outlines Standard	DIN 43700, ANSI C39.1
Protocol Conformance	IEC 61850 2nd Ed. BTL Listed for B-SA (Acuvim-CL, EL)

# FUNCTION LIST

● Function; ○ Option; Blank NA

REAL TIME MEASURING	Parameters	Acuvim-CL	Acuvim-EL
Phase Voltage	V1, V2, V3, Vlnavg	●	●
Line Voltage	V12, V23, V31, Vllavg	●	●
Current	I1, I2, I3, In, Iavg	●	●
Power	P1, P2, P3, Psum	●	●
Reactive Power	Q1, Q2, Q3, Qsum	●	●
Apparent Power	S1, S2, S3, Ssum	●	●
Power Factor	PF1, PF2, PF3, PF	●	●
Frequency	F	●	●
Load Features	L/C/R	●	●
Four Quadrant Powers	Four Quadrant Powers	●	●
<b>INDEPENDENT CHANNEL</b>			
System Phase Voltage	V1, V2, V3, Vlnavg	●	●
System Line Voltage	V12, V23, V31, Vllavg	●	●
System Frequency	F	●	●
Current	Ichannel1, Ichannel2, Ichannel3, Ichannel4, Isum_1avg, Isum_2avg	●	●
Power	Pchannel1, Pchannel2, Pchannel3, Pchannel4, Psum_1, Psum_2	●	●
Reactive Power	Qchannel1, Qchannel2, Qchannel3, Qchannel4, Qsum_1, Qsum_2	●	●
Apparent Power	Schannel1, Schannel2, Schannel3, Schannel4, Ssum_1, Ssum_2	●	●
Power Factor	PFchannel1, PFchannel2, PFchannel3, PFchannel4, PFsum_1, PFsum_2	●	●
Load Features	Load Features	●	●
Four Quadrant Powers	Four Quadrant Powers	●	●
Energy	Epchannel1_imp, Epchannel2_imp, Epchannel3_imp, Epchannel4_imp Epchannel1_exp, Epchannel2_exp, Epchannel3_exp, Epchannel4_exp Epsum1_imp, Epsum2_imp, Epsum1_exp, Epsum2_exp Epsum1_Total, Epsum2_Total, Epsum1_Net, Epsum2_Net	●	●
Reactive Energy	Eqchannel1_imp, Eqchannel2_imp, Eqchannel3_imp, Eqchannel4_imp, Eqchannel1_exp, Eqchannel2_exp, Eqchannel3_exp, Eqchannel4_exp, Eqsum1_imp, Eqsum2_imp, Eqsum1_exp, Eqsum2_exp, Eqsum1_Totoal, Eqsum2_Total, Eqsum1_Net, Eqsum2_Net	●	●
Apparent Energy	Eschannel1, Eschannel2, Eschannel3, Eschannel4, Essum1, Essum2	●	●
Demand	Dmd_Pchannel1, Dmd_Pchannel2, Dmd_Pchannel3, Dmd_Pchannel4, Dmd_Qchannel1, Dmd_Qchannel2, Dmd_Qchannel3, Dmd_Qchannel4, Dmd_Schannel1, Dmd_Schannel2, Dmd_Schannel3, Dmd_Schannel4, Dmd_Psum1, Dmd_Psum2, Dmd_Qsum1, Dmd_Qsum2 Dmd_Ssum1, Dmd_Ssum2, Dmd_Ichannel1, Dmd_Ichannel2, Dmd_Ichannel3, Dmd_Ichannel4	●	●
<b>ENERGY</b>			
Active Energy	Ep_imp, Ep_exp, Ep_total, Ep_net, Epa_imp, Epa_exp, Epb_imp, Epb_exp, Epc_imp, Epc_exp, Ep_q1, Ep_q2, Ep_q3, Ep_q4	●	●
Reactive Energy	Eq_imp, Eq_exp, Eq_total, Eq_net, Eqa_imp, Eqa_exp, Eqb_imp, Eqb_exp, Eqc_imp, Eqc_exp	●	●
Apparent Energy	Es_imp, Es_exp, Es_total, Es_net, Esa, Esb, Esc, Es_q1, Es_q2, Es_q3, Es_q4	●	●
<b>DUAL SOURCE ENERGY</b>			
Energy to Generator	Energy1_Generator, Energy2_Generator, Energy3_Generator	●	●
Energy to Grid	Energy1_Grid, Energy2_Grid, Energy3_Grid	●	●
<b>DEMAND</b>			
Current Demand	Dmd_I1, Dmd_I2, Dmd_I3, Dmd_In	●	●
Power Demand	Dmd_Psum, Dmd_Qsum, Dmd_Ssum	●	●
<b>TIME</b>			
Real-Time Clock	Year, Month, Day, Hour, Minute, Second	●	●

# FUNCTION LIST

● Function; ○ Option; Blank NA

HOUR				
Meter Running Time	Hour		●	●
Load Running Time	Hour		●	●
POWER QUALITY				
Voltage Unbalance	U_unbl		●	●
Current Unbalance	I_unbl		●	●
Voltage THD	THD_V1,THD_V2,THD_V3, THD_Vavg		●	●
Current THD	THD_I1, THD_I2, THD_I3, THD_lavg		●	●
Individual Harmonics	Harmonics 2nd to 31st		●	
	Harmonics 2nd to 63rd			●
Voltage Crest Factor	Crest Factor		●	●
TIF	THFF		●	●
Current K Factor	K Factor		●	●
SEQUENCE				
Voltage/Current Sequence	Positive Sequence, Negative Sequence, Zero Sequence		●	●
Phase Order	ABC, ACB		●	●
PHASE ANGLES				
Voltage/Current Phase Angles	Voltage Phase Angle, Current Phase Angle		●	●
STATISTICS				
MAX with Time Stamp MIN with Time Stamp	Each Phase of V & I Total of P, Q, S, PF & F Demand of I1, I2, I3, IN, P, Q, & S Each Phase THD of V & I Unbalance Factor of V & I		●	●
ALARM				
Over/Under Limit Alarm	V, I, P, Q, S, PF, V_THD & I_THD Each Phase and Total/Average Unbalance Factor of V& I Load Type Analog and Digital Input of Each Channel Demand of I1, I2, I3, P, Q & S Reverse Phase Sequence		●	●
POWER QUALITY EVENT LOGGING				
Power Quality Event with Time Stamp	Voltage Sag and Swell			●
DATA LOGGING				
Data Logging 1 Data Logging 2 Data Logging 3 Data Logging 4	Frequency V1, V2, V3, Vinavg V12, V23, V31, Vllavg I1, I2, I3, In, Iavg P1, P2, P3, Psum Q1, Q2, Q3, Qsum S1, S2, S3, Ssum Ep_imp, Ep_exp, Ep_total, Ep_net, Eq_imp, Eq_exp, Eq_total, Eq_net, Es_imp, Es_exp, Es_total, Es_net Epa_imp, Epa_exp, Epb_imp, Epb_exp, Epc_imp, Epc_exp Eq_a_imp, Eq_a_exp, Eq_b_imp, Eq_b_exp, Eq_c_imp, Eq_c_exp Esa_imp, Esa_exp, Esb_imp, Esb_exp, Esc_imp, Esc_exp PF1, PF2, PF3, PF U_unbl, I_unbl Load Type THD_V1, THD_V2, THD_V3, THD_Vavg THD_I1, THD_I2, THD_I3, THD_lavg Harmonics 2nd to 63rd, Crest Factor, THFF, K Factor Sequence, phase angles DI counter, AI, AO Dmd P, Dmd Q, Dmd S, Dmd_I1, Dmd_I2, Dmd_I3		●	●





## FUNCTION LIST

● Function; ○ Option; Blank NA



TIME OF USE				
Energy/Max Demand	TOU, 4 Tariffs, 12 Seasons, 14 Schedules		●	●
Daylight Saving Time	Two Adjustable Formats		●	●
I/O MODULE				
Switch Status (DI)	Digital Input		○	○
Power Supply for DI	24V DC		○	○
Relay Output (RO)	NO, Form A		○	○
Digital Output (DO)	Photo-MOS		○	○
Pulse Output (PO)	By Using DO		○	○
Analog Input (AI)	0 (4) – 20mA, 0 (1) – 5V		○	○
Analog Output (AO)	0 (4) – 20mA, 0 (1) – 5V		○	○
COMMUNICATION				
RS485 Port, Half Duplex, Optical Isolated	Modbus-RTU/BACnet Protocol		●	●
Ethernet Module	Modbus-TCP, HTTP, SMTP, SNMP, Modbus Gateway Passthrough		○	○
RS-485 Module	Modbus-RTU Protocol		○	○
ONBOARD MEMORY SIZE				
Memory	Bytes		8MB	16MB (8MB Data Logging + 8MB Power Quality)
DISPLAY				
LCD or DIN Rail			○	○
DIMENSIONS				
96×96×64.3mm (Opening Size: 92 × 92mm)				

## COMMUNICATION MODULES

● Function; ○ Option; Blank NA

	Standard	AXM WEB2 FOLC	AXM WEB2	AXM WEB2-D	AXM-NET2	AXM RS485
						
Modbus-RTU	●					●
BACnet-MS/TP	●					
DNP 3.0 V2 Over IP		●	●	●		
IEC 61850 2nd Ed.		●	●	●		
Modbus-TCP		●	●	●	●	
HTTP/HTTPS Webserver		●	●	●	●	
SMTP Email		●	●	●		
SNMP V3		●	●	●		
Time Synchronization		NTP	NTP	NTP	SNTP	
EtherNet/IP		●	●	●		
MQTT		●	●	●		
RSTP		●	●	●	●	
IPv6		●	●	●		
HTTP/HTTPS Push		●	●	●		
AcuCloud		●	●	●	●	
FTP Post		●	●	●		
sFTP Server		●	●	●		
Datalogging	8MB	8GB	8GB	8GB		
BACnet-IP		●	●	●		
PROFINET		●	●	●		
Wi-Fi		●	●			
RJ45 Ports		1	2	2	2	
Fiber Optics LC		●				

## IO MODULES

	AXM-IO1	AXM-IO2	AXM-IO3
			
Digital Input ( <i>Dry</i> )	6	4	4
Digital Output		2	
Relay Output	2		2
Analogue Inputs			2
Analogue Outputs		2	
Power Supply	24Vdc		

## DIMENSIONS

### Acuvim L Dimensions

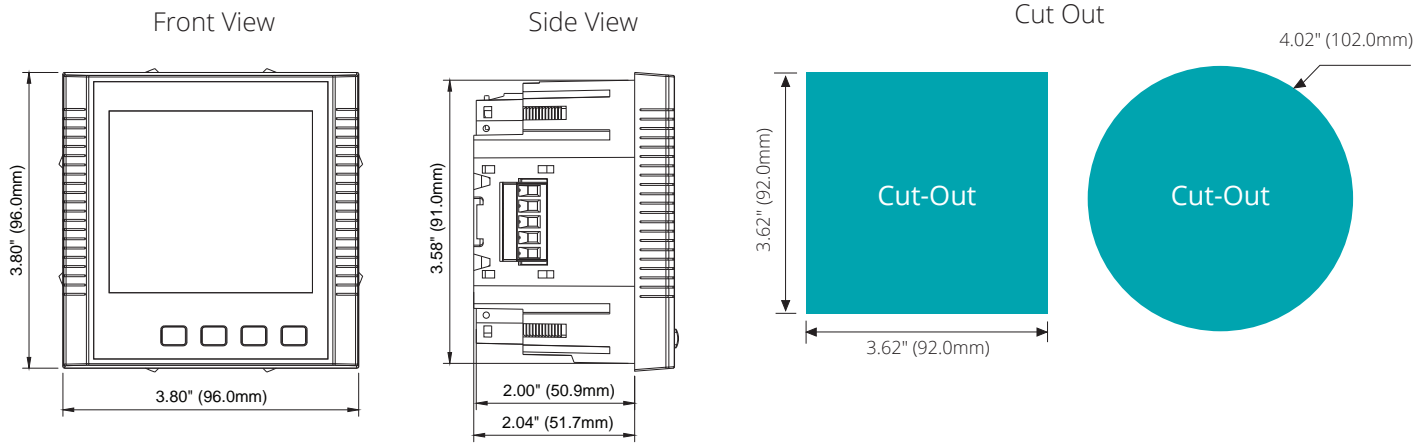

### DIN Mount Meter Dimensions

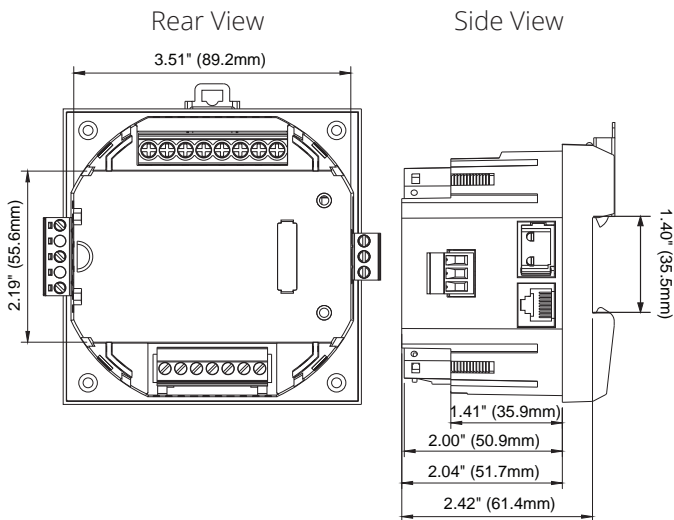

### External Display Module Dimensions

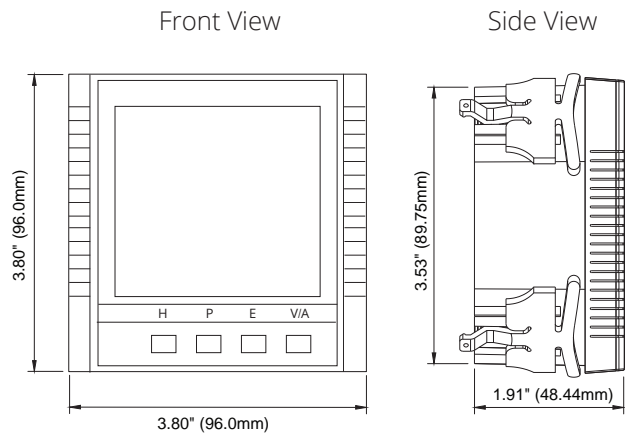

Note: 1. Display module is connected with a six-foot 10 pin RJ50 cable, if you need a longer cable please specify that in the ordering statement.

1. Display module opening size and Acuvim L body openings are exactly the same size.

### I/O Module Dimensions

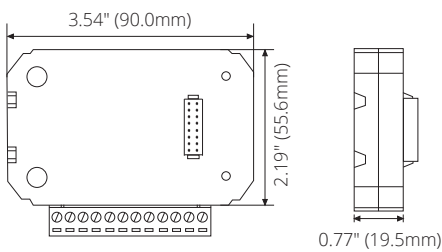

### Communication Module Dimensions

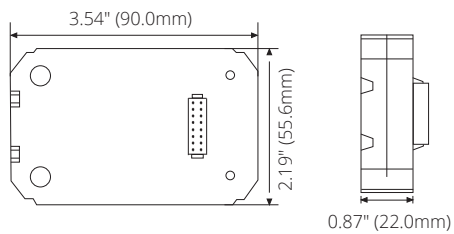

# WIRING DIAGRAMS

## Typical Wiring With 5A/1A CTs

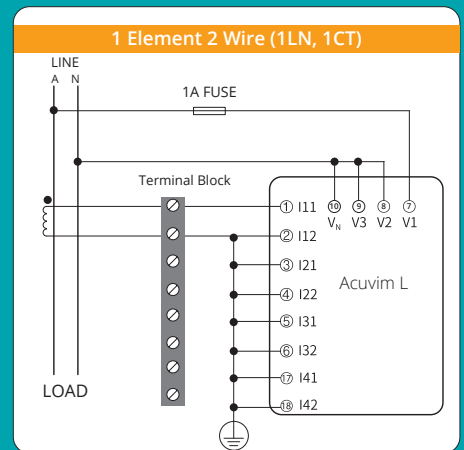
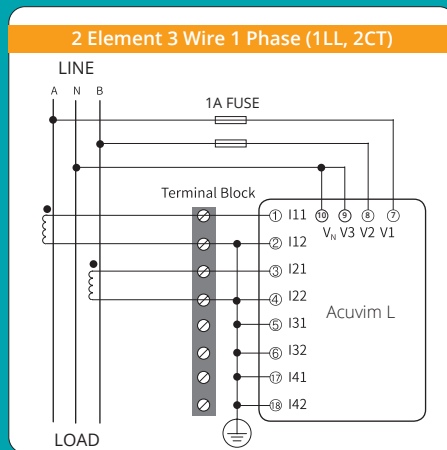
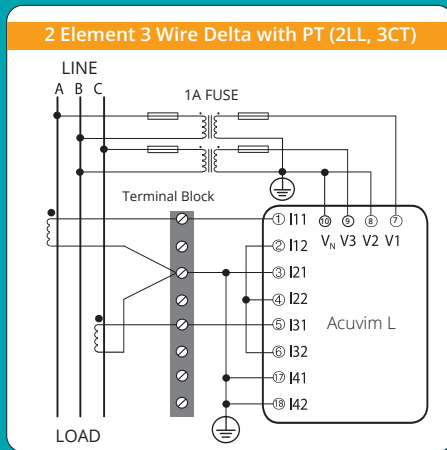
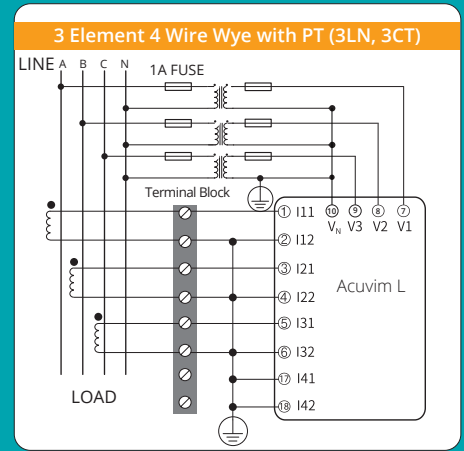
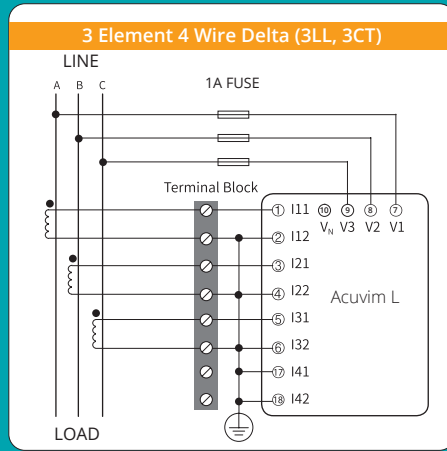
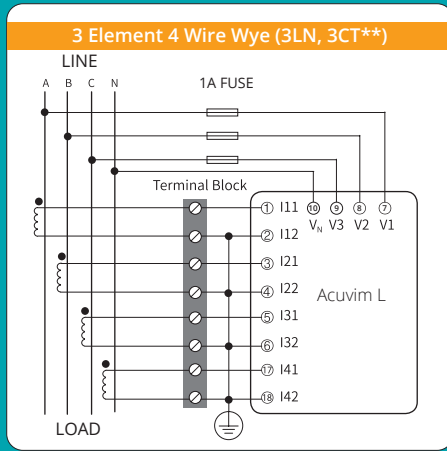

## I/O Module Wiring

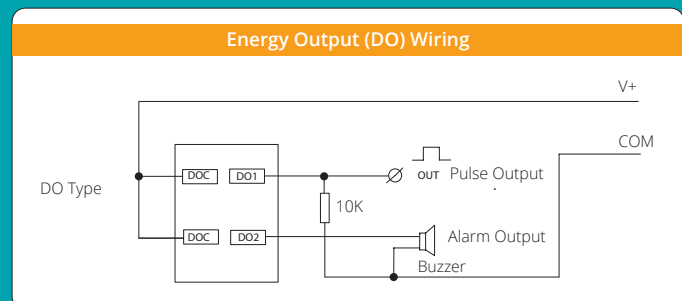
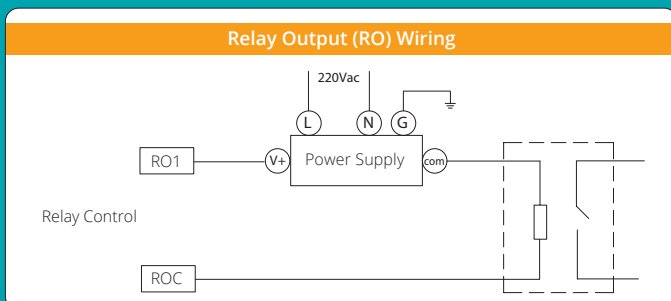
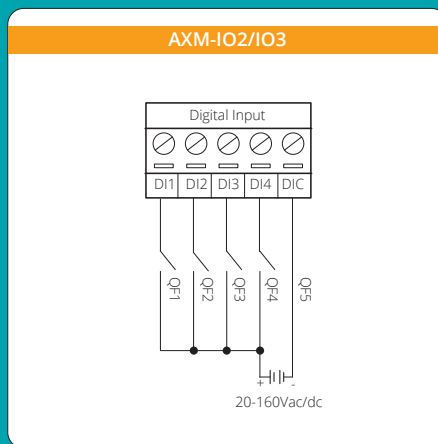
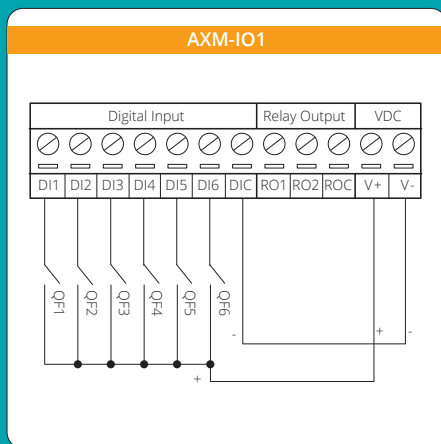

Note: \*2CT configuration is optional only in 3 Phase 3 Wire system.  
 \*\*Neutral CT is optional

## WIRING DIAGRAMS

### Typical Wiring RCT/mV Current Input

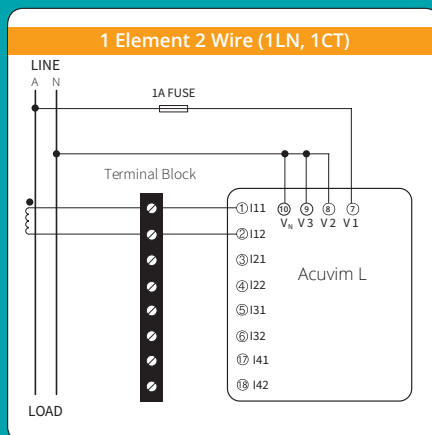
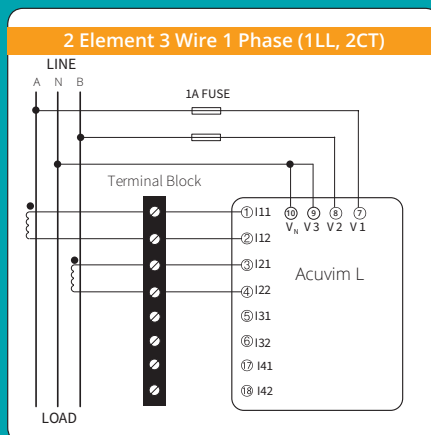
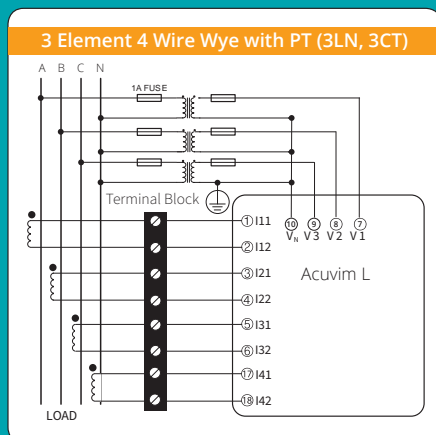
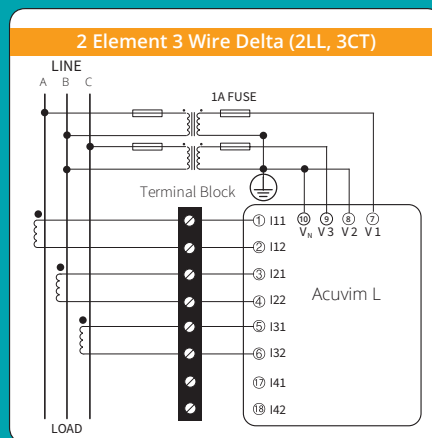
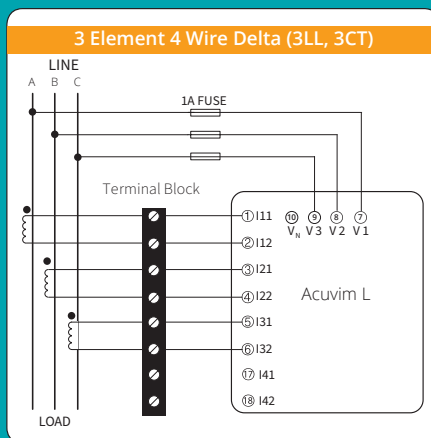
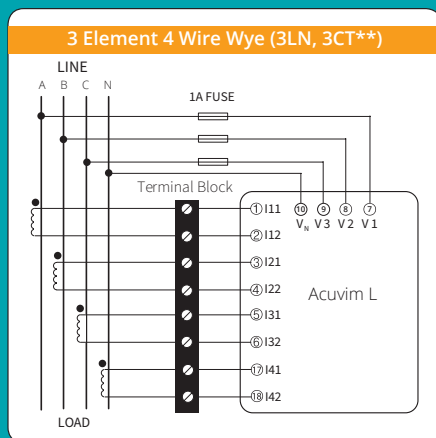

Note: \*2CT configuration is optional only in 3 Phase 3 Wire system.  
 \*\*Neutral CT is optional

## ACCESSORIES

### DIN Rail Adapter

The AXM-DIN Rail Adapter is the easy way to mount the Acuvim L Series energy meter on either horizontal or vertical DIN rail. The adapter quickly secures to the meter and is compatible with all AXM communication modules as well as I/O options.

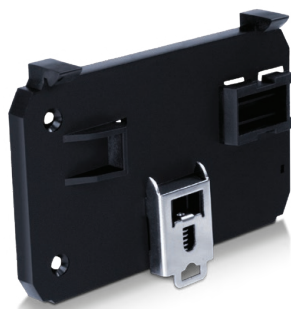

### Protective Display Cover

The Protective Display Cover is designed for Acuvim L Series energy meters and other 96mm by 96mm display panel meters. Crucial in harsh environments, it increases the IP environmental rating of a meter's display to IP66 or NEMA 4X.



### USB RS485 Converter

This plug-and-play USB to Serial RS485 Converter is designed to provide a convenient, reliable USB connection to the Acuvim L Series power meters and other serial devices.



## ORDERING INFORMATION

+ Meter Model	- Mounting Option	- Current Input	- Power Supply
<b>Acuvim-CL Energy class:</b> 0.5 Harmonics up to 31st	<b>D:</b> LCD Display (Panel Mount Meter/Transducer)	<b>5A:</b> 5A/1A (Input Field Selectable)	<b>P1V4:</b> 100~415Vac, 50/60Hz, 100~300Vdc
<b>Acuvim-EL Energy class:</b> 0.2 Harmonics up to 63rd	<b>M:</b> DIN-Rail Mount Transducer without Display (Optional Remote Display Available)	<b>mV:</b> 333mV and Rogowski Coil (Input Field Selectable)	<b>P2V4:</b> 20~60Vdc
<b>Ordering Example:</b>	<b>Acuvim-CL-M-mV-P2V4</b>		
	<b>Acuvim-EL-D-5A-P1V4</b>		

- Note:**
1. Accuenergy suggests using USB-RS485 converter for configuration, and 3 CTs per three phase circuits.
  2. All fields must be completed to create a part number.
  3. Add "S" after power supply for anti-tampering seal option.

+ Communication Module (Optional)	- Protocols
<b>AXM</b>	<b>WEB2-FOLC:</b> IEC 61850 2nd Ed., Modbus-TCP, HTTP/HTTPS Webserver, SMTP Email, SNMP, HTTP/HTTPS Push, FTP Post, sFTP Server, BACnet-IP, Datalogging, Wi-Fi, Fiber Optics LC, Ethernet Port, EtherNet/IP, MQTT, Modbus Gateway Passthrough
	<b>WEB2:</b> IEC 61850 2nd Ed., Modbus-TCP, HTTP/HTTPS Webserver, SMTP Email, SNMP, HTTP/HTTPS Push, FTP Post, sFTP Server, BACnet-IP, Datalogging, Wi-Fi, Dual Ethernet Ports, EtherNet/IP, MQTT, Modbus Gateway Passthrough
	<b>WEB2-D:</b> IEC 61850 2nd Ed., Modbus-TCP, HTTP/HTTPS Webserver, SMTP Email, SNMP, HTTP/HTTPS Push, FTP Post, sFTP Server, BACnet-IP, Datalogging, Dual Ethernet Ports, EtherNet/IP, MQTT, Modbus Gateway Passthrough
	<b>RS485:</b> Modbus-RTU
	<b>NET2:</b> Modbus-TCP, HTTPS Web Interface, SNTP Time Synchronization, AcuCloud HTTPS Data Post
<b>Ordering Example:</b>	<b>AXM-RS485</b>
	<b>AXM-WEB2-FOLC</b>

+ I/O Module (Optional)	+ Accessories (Optional)
<b>AXM-IO1</b> 6 Digital Inputs, 2 Relay Outputs, 24Vdc Power Supply	<b>REM-DS1V4:</b> Remote Display (Only for Acuvim L DIN-Rail Mount "M" option)
<b>AXM-IO2</b> 4 Digital Inputs, 2 Digital Outputs, 2 Analog Outputs (0~5V or 1~5V, 0~20mA or 4~20mA)	<b>AXM-DIN:</b> DIN Rail Adapter
<b>AXM-IO3</b> 4 Digital Inputs, 2 Relay Outputs, 2 Analog Inputs (0~5V or 1~5V, 0~20mA or 4~20mA)	<b>IP66/NEMA4X:</b> Environmental Protection Cover
<b>Ordering Example:</b> <b>AXM-IO1</b>	<b>USB-RS485:</b> USB-to-RS485 Converter

- Note:**
1. Refer to the Communication table and I/O Module table.
  2. A maximum of 3 modules may be attached to the meter. If a communication module is used (e.g. AXM-WEB2), it must be installed on the back FIRST before the other I/O modules are attached.
  3. No more than 2 of the same I/O modules may be attached to the meter (e.g. two AXM-IO2). The same two I/O modules must have different logic numbers. Logic numbers can be configured through Acuvim 2 or AXM-WEB2.



### Accuenergy Inc.

Los Angeles - Toronto - Pretoria  
 North America Toll Free: 1-877-721-8908  
 Web: [www.accuenergy.com](http://www.accuenergy.com)  
 Email: [marketing@accuenergy.com](mailto:marketing@accuenergy.com)

Revision Date: June 2026 Version: 2.0.18  
 Specs Subject To Change Without Notice.



ISO 9001, 14001  
& 45001 Certified



ISO 27001 &  
50001 Certified

